

APPLICATION:

PRODUCT NAME:

8" ADJ. SERVICE SINK FAUCET WITH  
SHORT SPOUT AND VACUUM BREAKER

JOB NAME:

SPECIAL CONFIGURATION  
 CHECK BASE MODEL AND OPTIONS

QUANTITY:

ITEM NO.

MODEL:

2453 WITH ECCENTRIC STOPS

OPTIONS OR MODIFICATIONS:

- SUPPLY LINES (24" OR 36") CIRCLE LENGTH
- NIPPLES
- ELBOWS
- VANDAL RESISTANT KIT
- HANDLES (CROSS OR WRIST) CIRCLE STYLE
- OTHER \_\_\_\_\_

FEATURES

CONTROL VALVE

- \* KEY-STOP ECCENTRICS ADJUST FROM 5" TO 11-1/2"
- \* INTERNAL SPRING LOADED CHECK VALVES
- \* SWIVELLING SEAT DISKS
- \* HOT SIDE STEM - RIGHT HAND
- \* COLD SIDE STEM - LEFT HAND
- \* ECCENTRICS STEMS - RIGHT HAND - SWIVELLING SEAT DISKS
- \* STAINLESS STEEL SEATS
- \* STAINLESS STEEL SEAT SCREWS
- \* STAINLESS STEEL HANDLE SCREWS
- \* ATMOSPHERIC VACUUM BREAKER

SYSTEM LIMITS

- \* TEMP: 40°F MIN. TO 140°F MAX.
- \* PRESSURE: 200 PSI MAX. STATIC

SHIPPING WEIGHT

\* 6.85 LBS

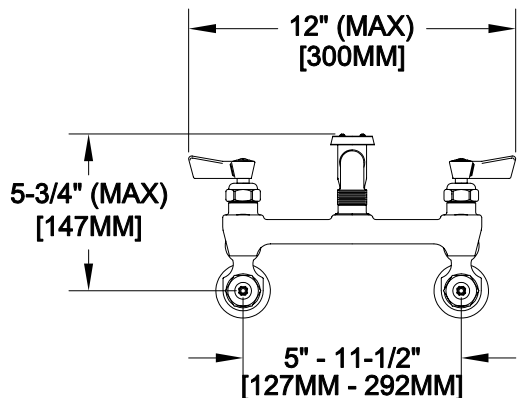

ROUGH-IN:

